

納 入 図 書

品名 キーロン VF 継手

株式会社 協 成

エルボ(L)



図-1

表-1

単位 : mm

呼び径		S	A	φD
A 呼称	B 呼称			
20	3/4	19.5	52	41
25	1	23.5	61	49
32	1 1/4	24	70	58
40	1 1/2	24.5	72	65
50	2	25	83	78.5
65	2 1/2	26.5	96	100
80	3	26.5	107	115.5
100	4	27.5	127.5	143.5

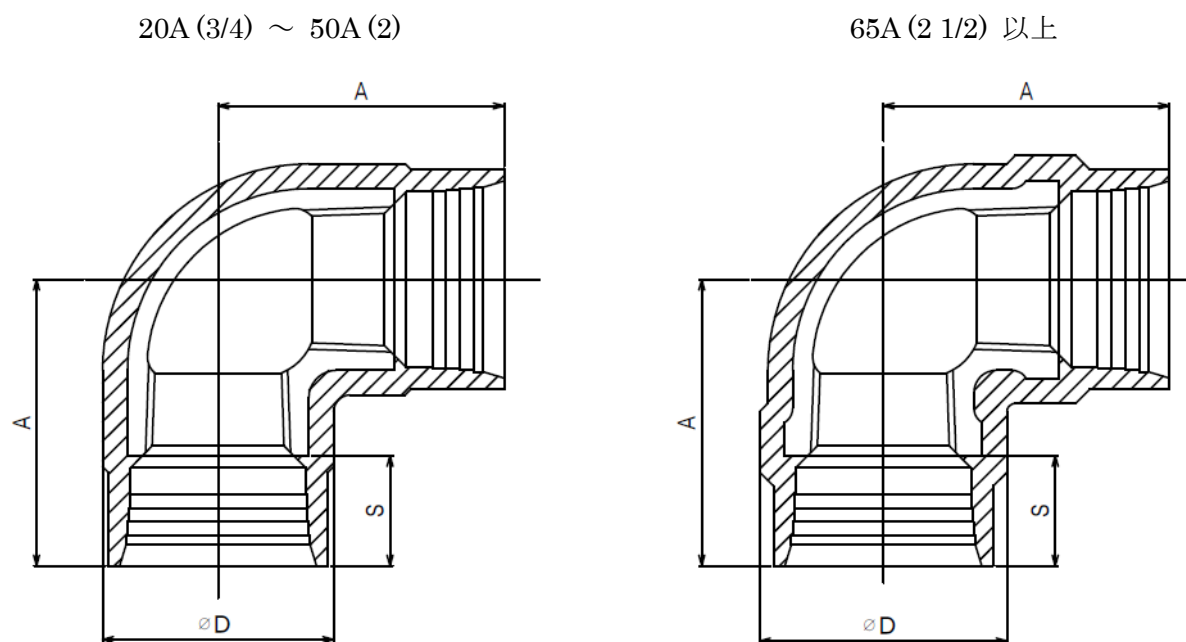
径違いエルボ (RL)

40A (1 1/2) ~ 50A (2)

65A (2 1/2) 以上



図-2

表-2

単位 : mm

呼び径		S1	S2	A	B	φ D1	φ D2
A 呼称 (①×②)	B 呼称 (①×②)						
50×40	2×1 1/2	24.5	24	77.5	79	78.5	65
65×50	2 1/2×2	26	25	87	91	100	82
80×65	3×2 1/2	27	26	100	102	115	100
100×65	4×3	28	27	110	117	143	115

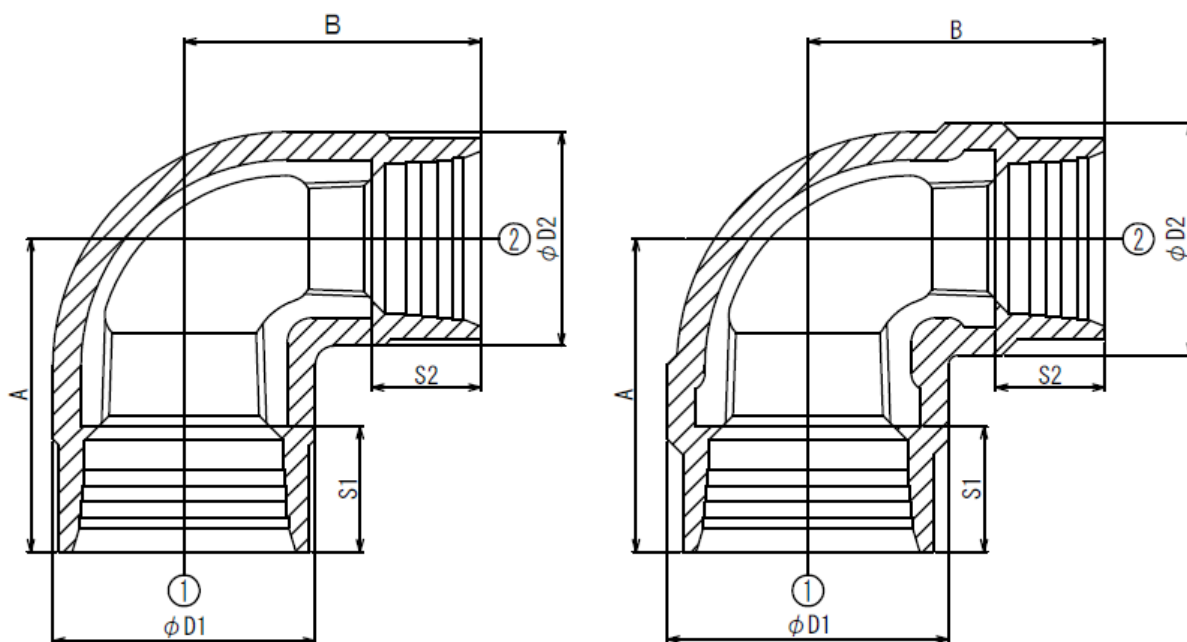
チーズ(T)

20A (3/4) ~ 50A (2)

65A (2 1/2) 以上



図-3

表-3

単位 : mm

呼び径		S	A	φD
A 呼称	B 呼称			
20	3/4	19	52	41.5
25	1	23.5	62	49.5
32	1 1/4	24	70.5	58.5
40	1 1/2	24	72.5	65.5
50	2	24.5	81	78
65	2 1/2	26.5	96.5	100
80	3	26.5	106	115
100	4	28	127.5	143

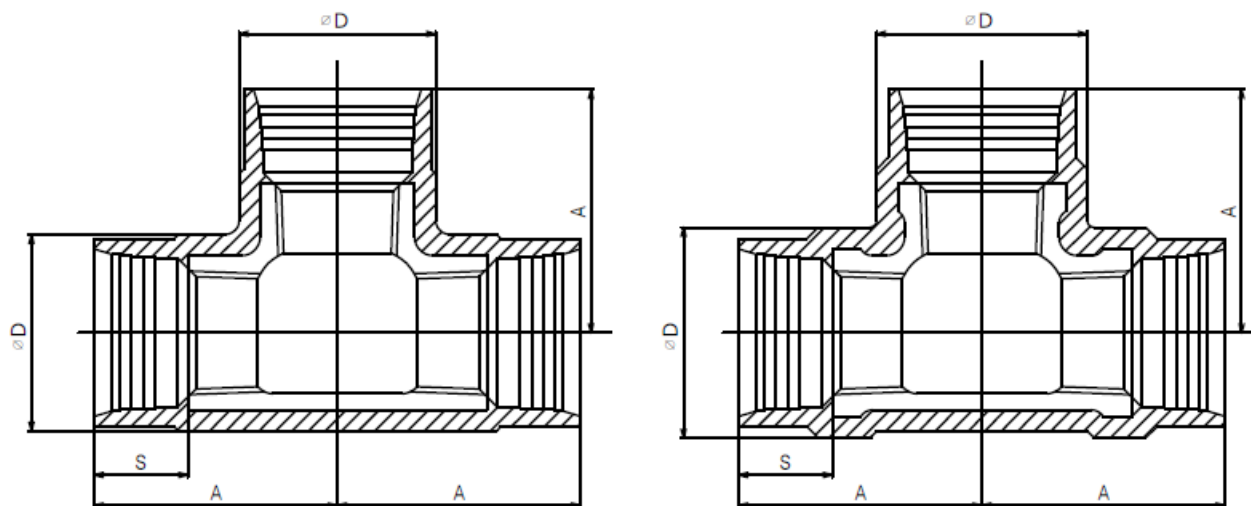
径違いチーズ(RT)

20A (3/4) ~ 50A (2)

65A (2 1/2) 以上



図-4

表-4

単位 : mm

呼び径		S1	S2	A	B	φ D1	φ D2
A 呼称 (①×②×③)	B 呼称 (①×②×③)						
25×25×20	1×1×3/4	23	19	58	54.5	49.5	41
40×40×20	1 1/2×1 1/2×3/4	23.5	19	63	63	65.5	41.5
50×50×20	2×2×3/4	24	18.5	66	68.5	78	41.5
50×50×25	2×2×1	24	23	69	74.5	78	49
50×50×40	2×2×1 1/2	24	23.5	77	79.5	78	65
65×65×50	2 1/2×2 1/2×2	26.5	23.5	87.5	90	100	82
80×80×50	3×3×2	26.5	24.5	91	97.5	115	82
80×80×65	3×3×2 1/2	26.5	26.5	100	103	115	100
100×100×50	4×4×2	28	25	98	112	143	82
100×100×80	4×4×3	28.5	27	112	118.5	142.5	115

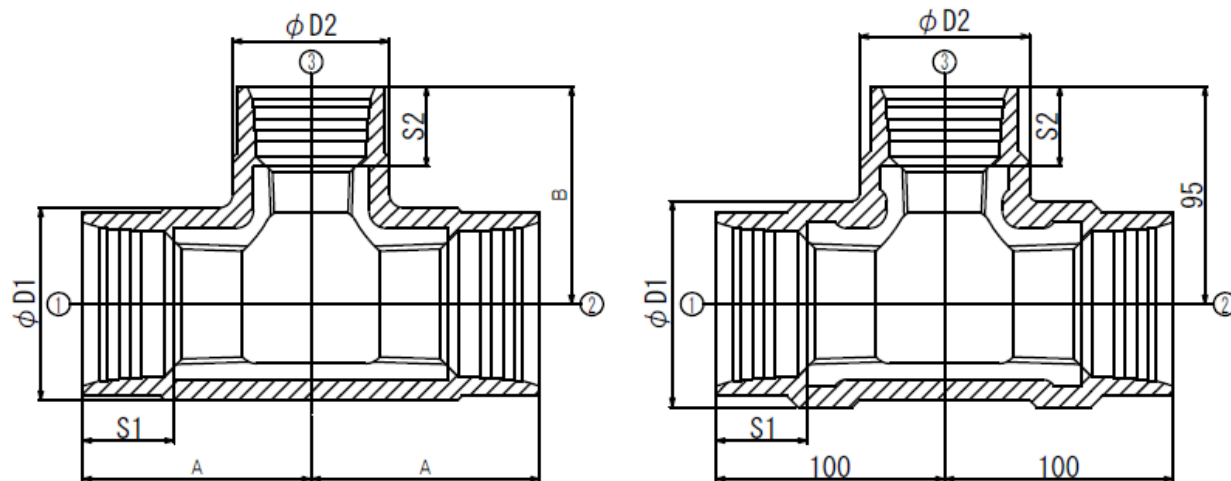
ソケット(S)



図-5

表-5

単位：mm

呼び径		S	L	φD
A呼称	B呼称			
20	3/4	18.5	78	44
25	1	23	93.5	52
32	1 1/4	24	99	61.5
40	1 1/2	23.5	104.5	68.5
50	2	24	111	81
65	2 1/2	26	126	100.5
80	3	26	130.5	115
100	4	28	146.5	143

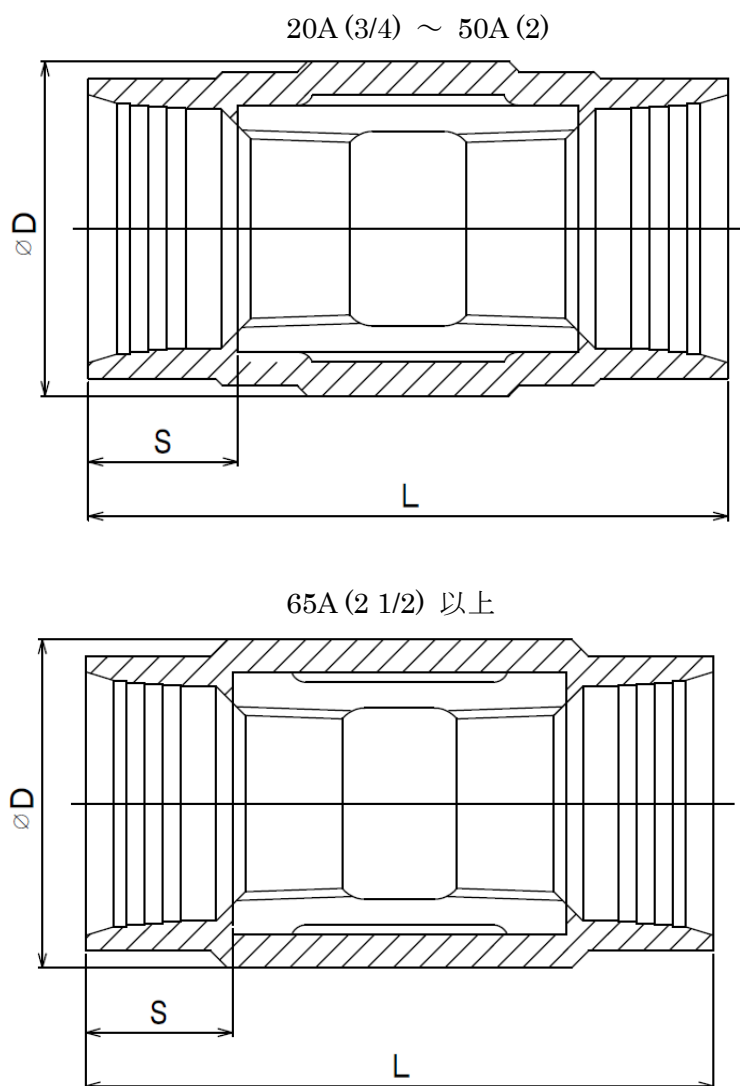
径違いソケット (RS)

20A (3/4) ~ 50A (2)

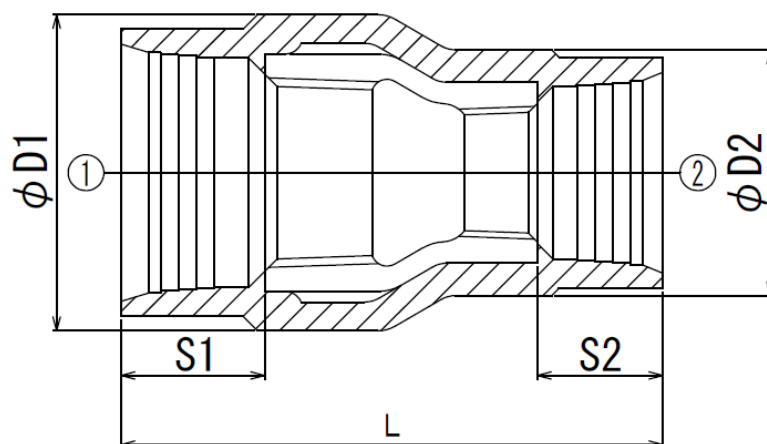

65A (2 1/2) 以上



図-6

表-6

単位：mm

呼び径		S1	S2	L	ϕ D1	ϕ D2
A 呼称 (①×②)	B 呼称 (①×②)					
25×20	1×3/4	23.5	19	86	52	41.5
40×20	1 1/2×3/4	23.5	19	94.5	69	41.5
40×25	1 1/2×1	23.5	23	98.5	69	49.5
40×32	1 1/2×1 1/4	23	23.5	101.5	69	58.5
50×40	2×1 1/2	24	23.5	108	81.5	65
65×50	2 1/2×2	26	23.5	118	100	82
80×50	3×2	26	24	125	115	82.5
80×65	3×2 1/2	26	26	126	115	100
100×65	4×2 1/2	28	26	140	143	100
100×80	4×3	27.5	26	140	143	115

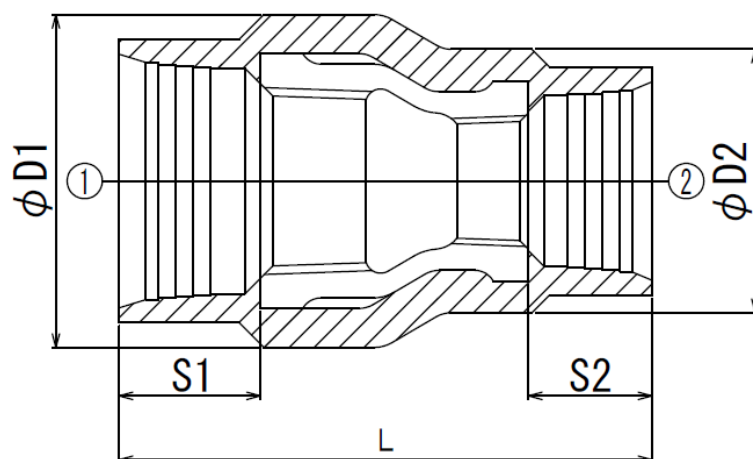
45° エルボ(45L)

20A (3/4) ~ 50A (2)

65A (2 1/2) 以上



図-7

表-7

単位 : mm

呼び径		S	A45°	D
A 呼称	B 呼称			
20	3/4	18.5	44.5	44.5
25	1	23.5	53	52
32	1 1/4	23.5	59	58.5
40	1 1/2	23	61.5	65.5
50	2	23.5	67.5	78
65	2 1/2	26.5	76	100
80	3	26	81.5	115
100	4	28.5	94	143.5

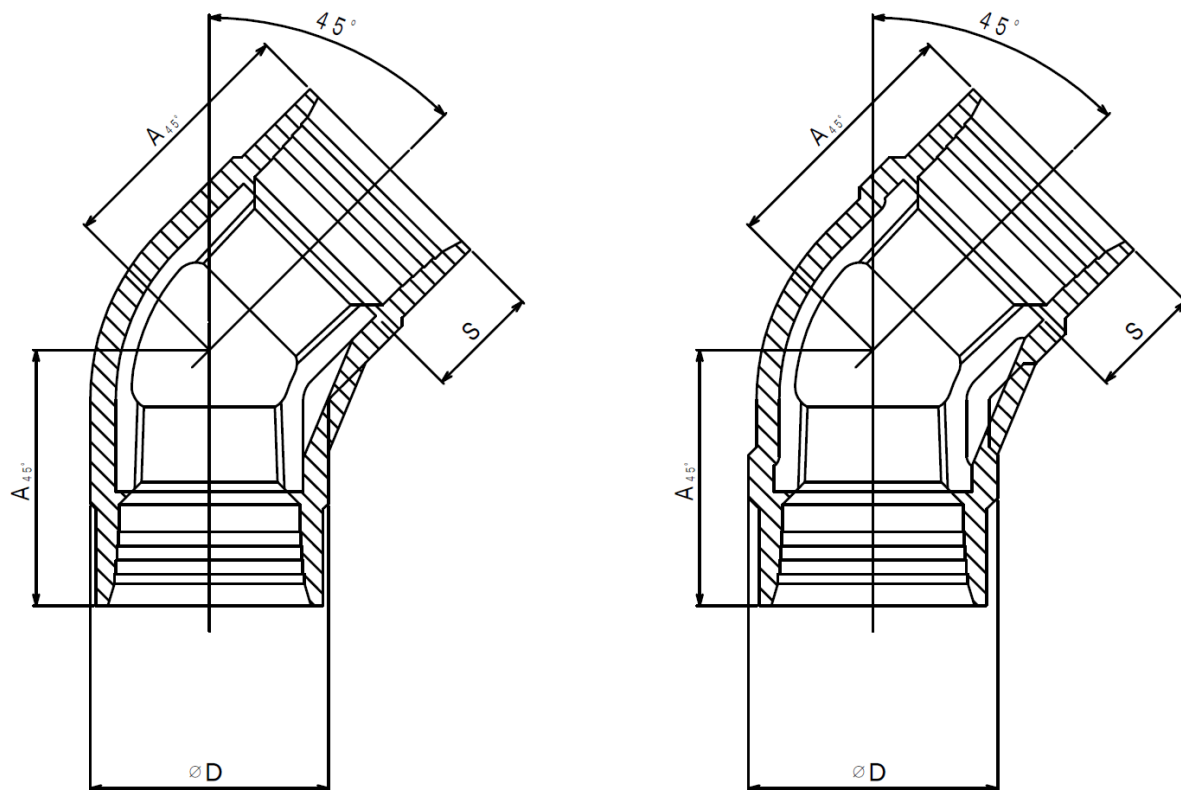
品 名 販 売	キーロン VF 継手	日 付	2021. 11
	株式会社 協 成	-	