

納 入 図 書

品名 キーロンVI継手

株式会社 協 成

エルボ(L)



図-1

表-1

単位：mm

呼び径		A	B	C	D
A 呼称	B 呼称				
15	1/2	47	34	20	34
20	3/4	52	40	20	40
25	1	62	48	24	48
32	1 1/4	70	57	24	57
40	1 1/2	72	63	24	63
50	2	82	76	25	76
65	2 1/2	95	98	26	92
80	3	105	112	27	106
100	4	125	140	28	132

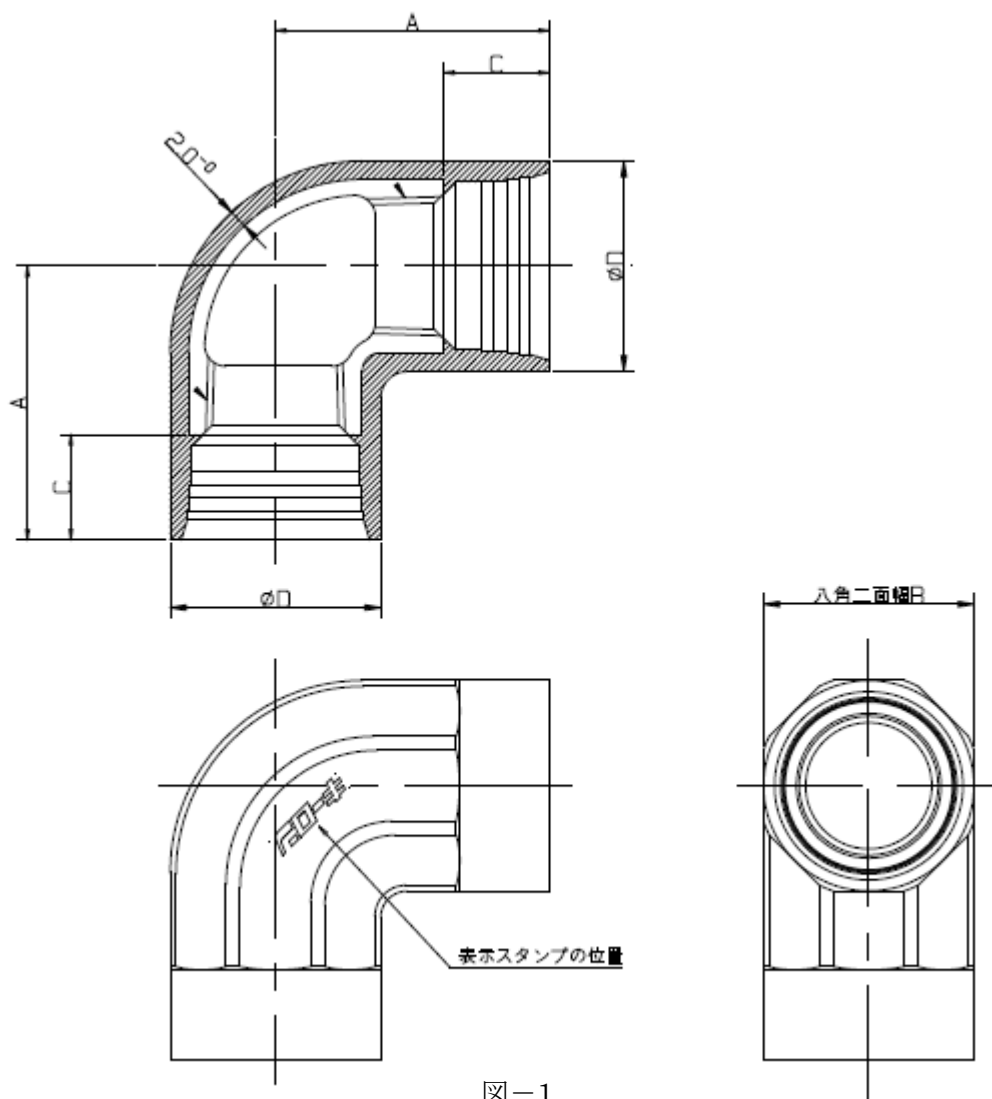
径違いエルボ(RL)



図-2

表-2

単位：mm

呼び径		A1	A2	B1	B2	C1	C2	D1	D2
A 呼称	B 呼称								
20×15	3/4×1/2	49	50	40	34	20	20	40	34
25×20	1×3/4	58	55	48	40	24	20	48	40
32×25	1 1/4×1	64	66	57	48	24	24	57	48
50×40	2×1 1/2	77	79	76	63	25	24	76	63
80×50	3×2	89	97	112	80	27	25	106	76
100×80	4×3	111	118	140	112	28	27	132	106

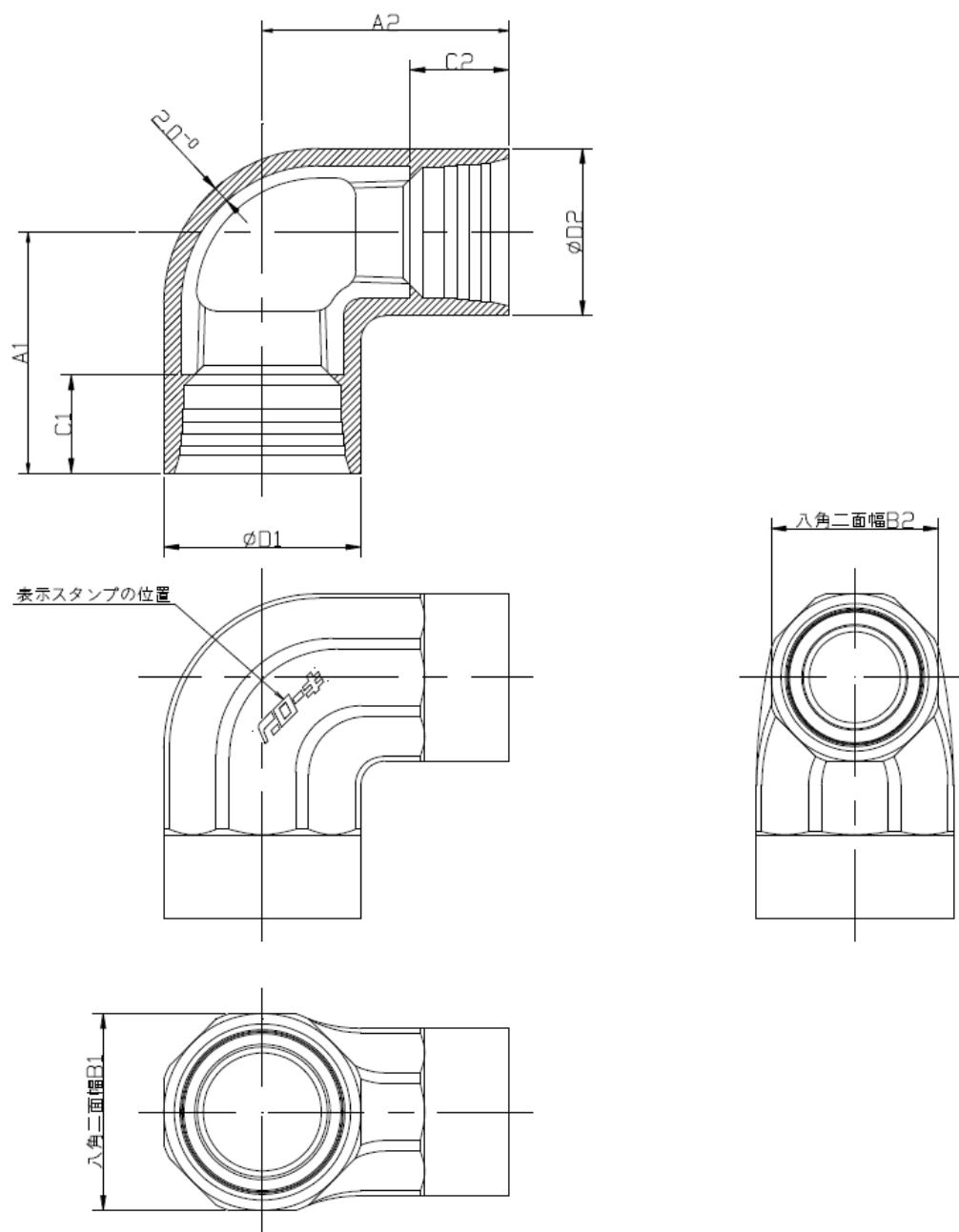
チーズ(T)



図-3

表-3

単位：mm

呼び径		A	B	C	D
A 呼称	B 呼称				
15	1/2	47	34	20	34
20	3/4	52	40	20	40
25	1	62	48	24	48
32	1 1/4	70	57	24	57
40	1 1/2	72	63	24	63
50	2	82	76	25	76
65	2 1/2	95	98	26	92
80	3	105	112	27	106
100	4	125	140	28	132

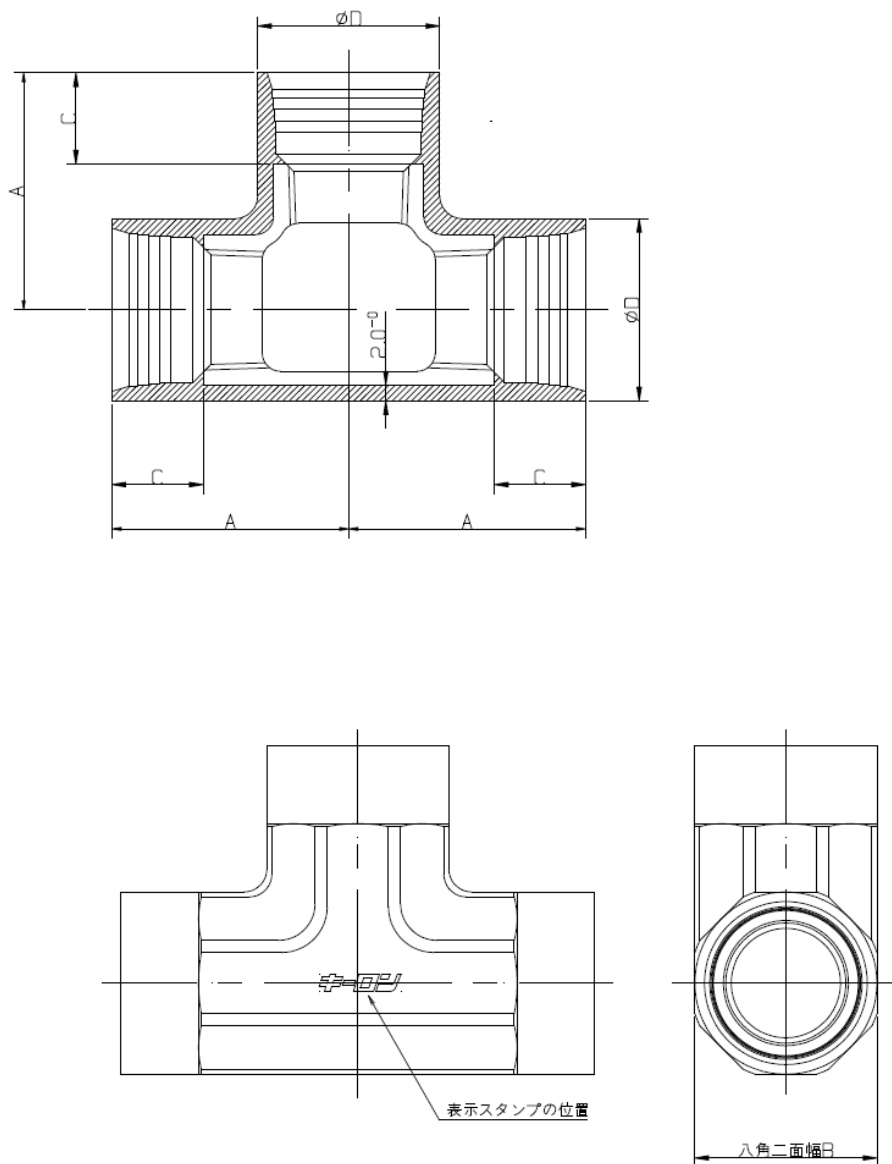
径違いチーズ(RT)



図-4

表-4

単位：mm

呼び径		A1	A2	B1	B2	C1	C2	D1	D2
A 呼称	B 呼称								
20×15	3/4×1/2	49	50	40	34	20	20	40	34
25×15	1×1/2	56	53	48	34	24	20	48	34
25×20	1×3/4	58	55	48	40	24	20	48	40
32×20	1 1/4×3/4	62	60	57	40	24	20	57	40
32×25	1 1/4×1	64	66	57	48	24	24	57	48
40×20	1 1/2×3/4	62	63	63	40	24	20	63	40
40×25	1 1/2×1	65	69	63	48	24	24	63	48
40×32	1 1/2×1 1/4	69	72	63	57	24	24	63	57
50×20	2×3/4	66	69	76	40	25	20	76	40
50×25	2×1	69	75	76	48	25	24	76	48
50×32	2×1 1/4	73	78	76	57	25	24	76	57
50×40	2×1 1/2	77	79	76	63	25	24	76	63
80×50	3×2	89	97	112	80	27	25	106	76
100×50	4×2	97	112	140	80	28	25	132	76
100×80	4×3	111	118	140	112	28	27	132	106

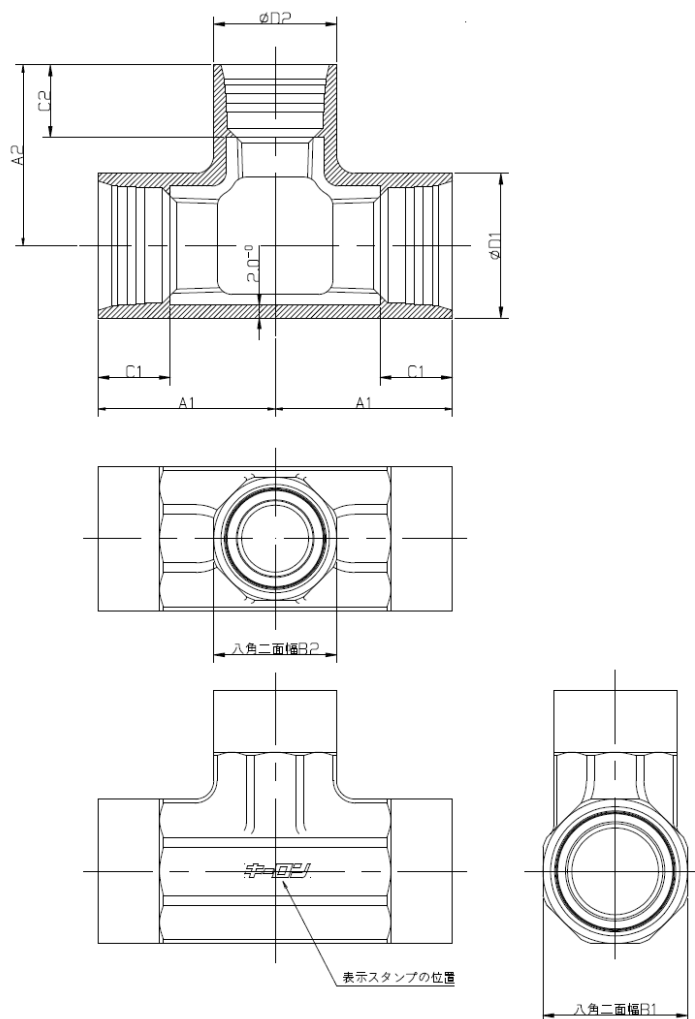
ソケット(S)



図-5

表-5

単位：mm

呼び径		A	B	C	D
A 呼称	B 呼称				
15	1/2	75	34	20	34
20	3/4	80	40	20	40
25	1	93	48	24	48
32	1 1/4	98	57	24	57
40	1 1/2	103	63	24	63
50	2	110	76	25	76
65	2 1/2	122	98	26	92
80	3	129	112	27	106
100	4	141	140	28	132

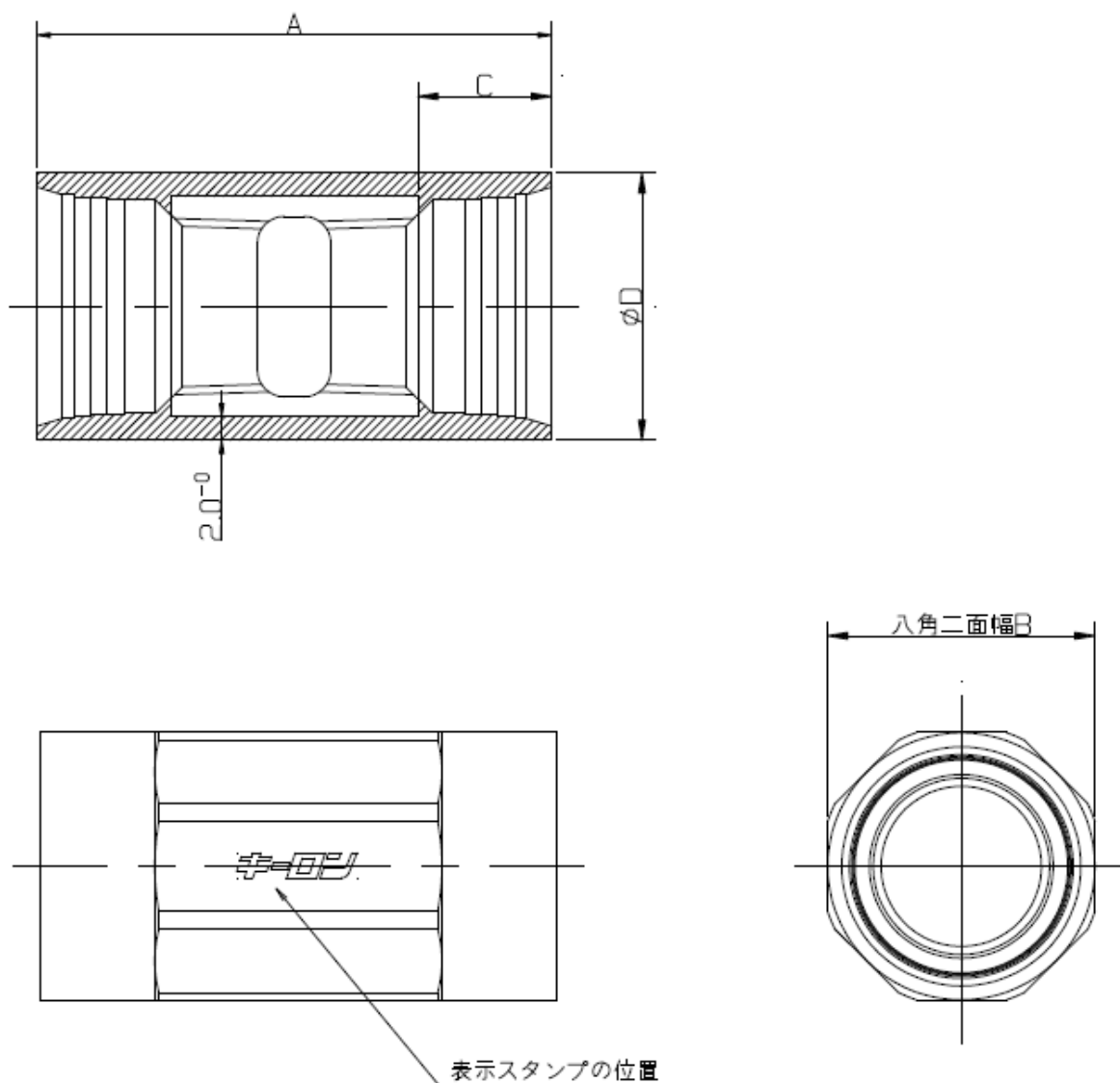
径違いソケット(RS)



図-6

表-6

単位: mm

呼び径		A	B1	B2	C1	C2	D1	D2
A 呼称	B 呼称							
20×15	3/4×1/2	77	40	34	20	20	40	34
25×20	1×3/4	86	48	40	24	20	48	40
32×25	1 1/4×1	96	57	48	24	24	57	48
40×25	1 1/2×1	100	63	48	24	24	63	48
40×32	1 1/2×1 1/4	100	63	57	24	24	63	57
50×40	2×1 1/2	107	76	63	25	24	76	63
80×50	3×2	124	112	80	27	25	106	76
80×65	3×2 1/2	125	112	98	27	26	106	92
100×80	4×3	140	140	112	28	27	132	106

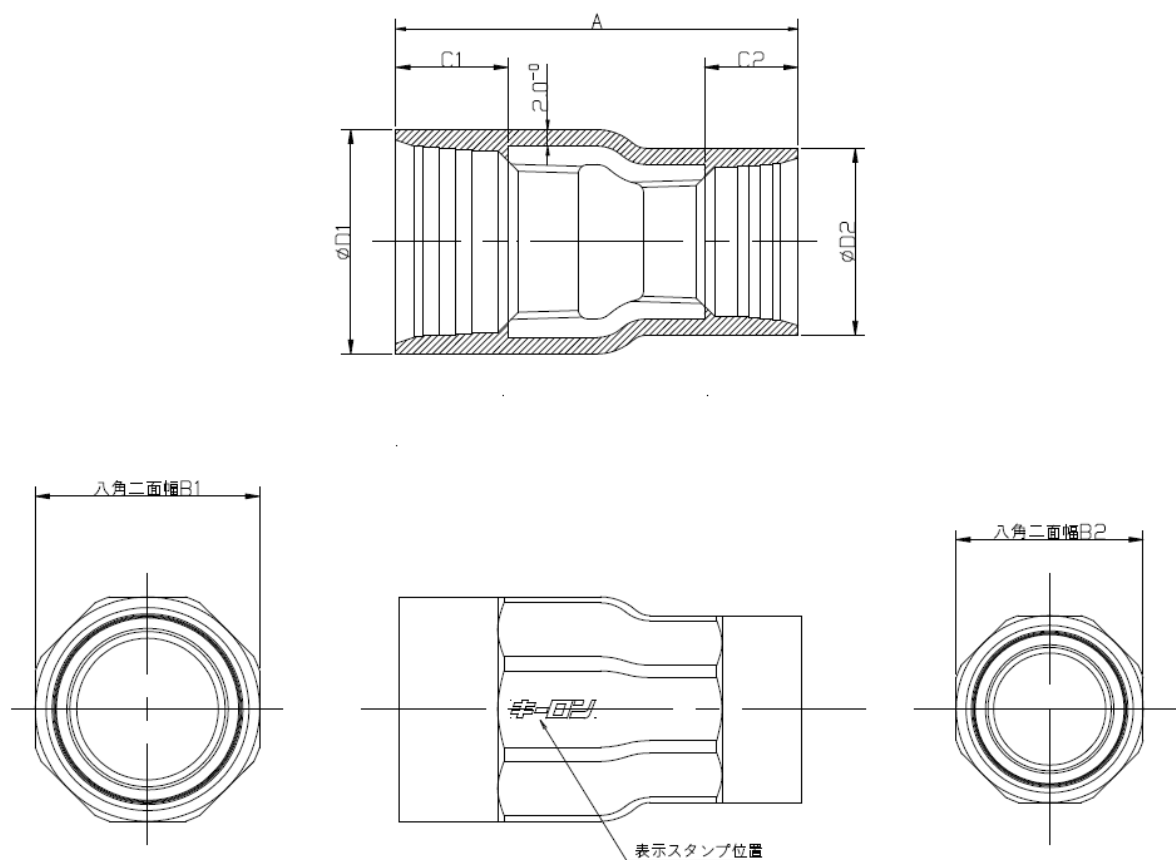
ストリートエルボ(SL)



図-7

表-7

単位 : mm

呼び径		A1	A2	B1	B2	C	D1	D2
A 呼称	B 呼称							
15	1/2	47	90	34	25	20	34	21.7
20	3/4	52	95	40	31	20	40	27.2
25	1	62	105	48	37	24	48	34
32	1 11/4	70	112	57	46	24	57	42.7
40	1 1/2	72	120	63	51	24	63	48.6
50	2	82	131	76	63	25	76	60.5

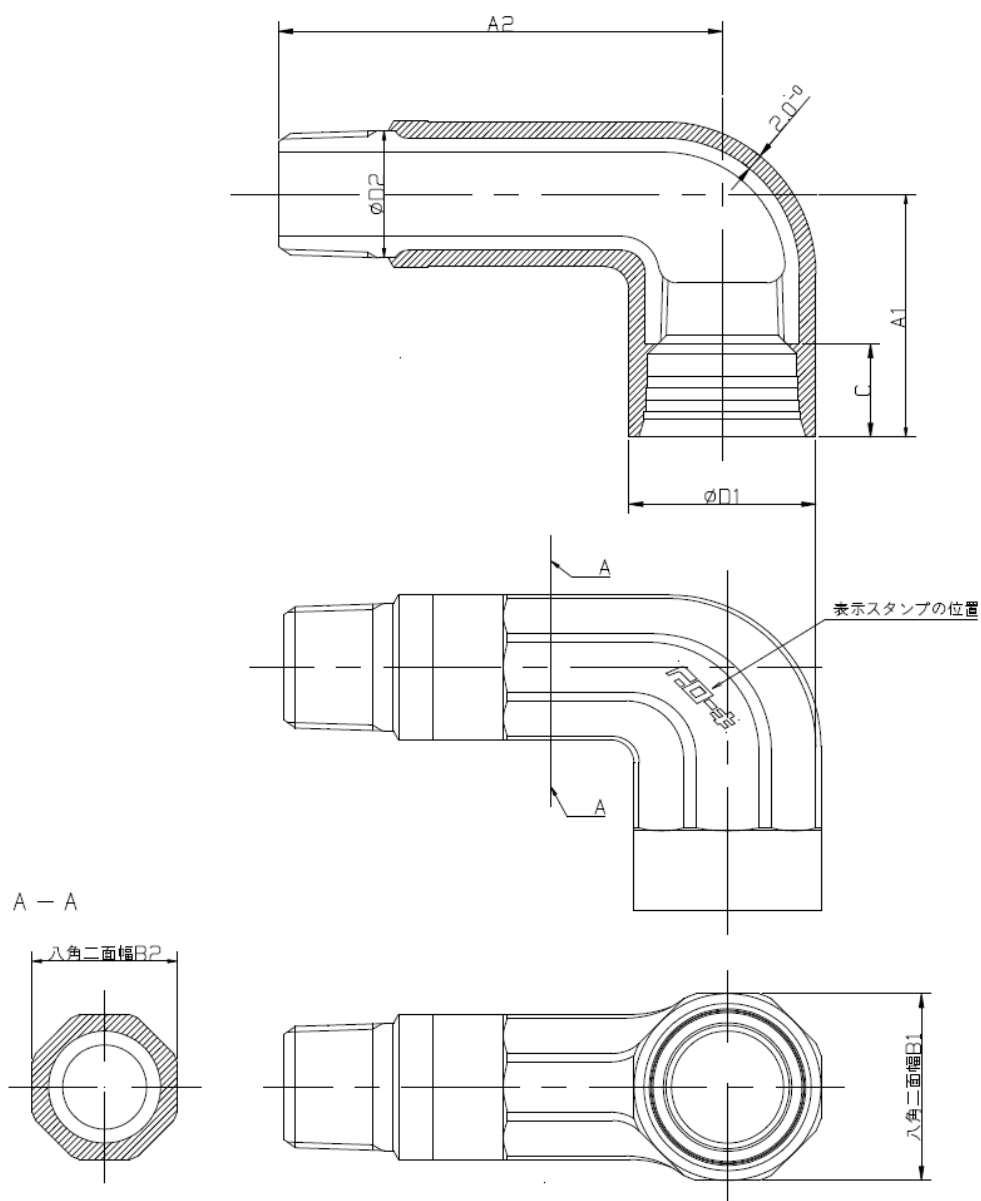
プラグ(P)

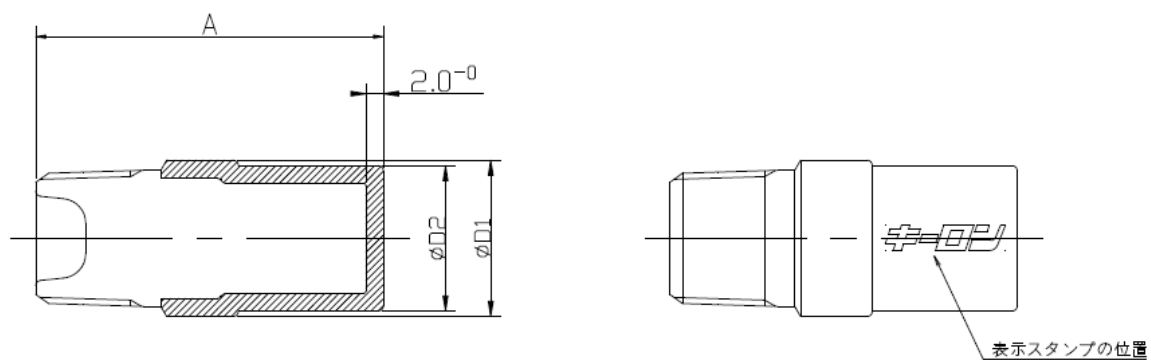

図-8

表-8 単位：mm

呼び径		A	D1	D2
A 呼称	B 呼称			
15	1/2	66.5	25.7	23
20	3/4	69.5	31.2	29
25	1	77.5	37.8	34
32	1 1/4	81.5	46.3	40
40	1 1/2	83.5	52.3	44
50	2	86.5	64.7	56

品名	キーロン VI 継手	日付	2021. 11
販売	株式会社 協成		—